

# Combo DB15 LCD Console Drawers – Short Depth

Optimize rack space. Maximize rack monitoring



LCD console drawer provides a variety of features that simplify to access servers to making system monitoring, troubleshooting and software upgrades.

The self-locking rails when in the fully extended open position and the ultra-convenient auto lock release when the LCD panel is closed, make for simple and hassle free operation.

Available with 15" or 17" A-Grade LCD panels, combo DB15 single, 8 or 16 port integrated KVM switch.

## Features

- Support combo interface, VGA-USB & VGA-PS/2.
- Short depth design suit for mobile rack and limited space.
- Durable 88-key keyboard and touch pad.
- Quick and simple installation.
- Self-locking and auto release rails for ultra-convenience.
- Port selection via push buttons or On-Screen-Display (OSD).
- Dedicated daisy chain port to expand up to 240 servers.



Rear of KVM-1501S/1701S-AST-M2



Rear of KVM-1508S/1708S-AST-M2



Rear of KVM-1516S/1716SAST-M2

Part No.	KVM-1501S-AST-M2	KVM-1508S-AST-M2	KVM-1516S-AST-M2	KVM-1701S-AST-M2	KVM-1708S-AST-M2	KVM-1716S-AST-M2
Direct no. of Computers	1	8	16	1	8	16
Maximum no. of Computers	1	232(Daisy Chain)	240(Daisy chain)	1	232(Daisy Chain)	240(Daisy chain)
LCD	Size	15"		17"		
	Backlight	LED		LED		
	Resolution	1024*768		1280*1024		
	Max.color	16.7M		16.7M		
	Luminance	450cd/m2		250cd/m2		
	View Angel (H/V)	160 / 140		176 / 170		
	Contrast Ratio	700 : 1		1000 : 1		
Port Selection	N/A	Push Button, OSD or Hotkey		N/A	Push Button, OSD or Hotkey	
USB Local console / Expansion Slot	N/A					
KB/Mouse Emulation	USB & PS2					
Rack Depth	360mm to 580mm ( rack cabinet front rails to rear rails )			380mm to 620mm ( rack cabinet front rails to rear rails )		
Power	100-240V AC 50/60Hz via IEC Type power cord					
Environment	Operation temp: 0 to 50 °C Storage temp: -20 to 60 °C Humidity: 10% - 90%, non-condensing Shock: 10G acceleration ( 11ms duration) Vibration: 17 to 500Hz 1G PTP					
Physical Dimensions / Net Weights	443x42x406.4mm (WxHxD) /12.5KG			443x42x457.2mm (WxHxD) /14KG		
Packing Dimensions / Gross weights	715x140x600mm (WxHxD) / 15.5KG			715x140x600mm (WxHxD) /17KG		
<b>Accessory</b>						
1.8meter IEC Type Power Cord (1.8meter VGA& PS2Cable + 1.8meter USB A Type Cable for KVM-1501S/1701S-AST-M2 )						
<b>Option Relate Item</b>						
CVU-018	1.8meter 2-in-1 KVM Cable-USB&VGA		CVP-018	1.8meter 3-in-1 KVM Cable-PS/2&VGA		
CVU-030	3.0meter 2-in-1 KVM Cable-USB&VGA		CVP-030	3.0meter 3-in-1 KVM Cable-PS/2&VGA		
CVU-050	5.0meter 2-in-1 KVM Cable-USB&VGA		CVP-050	5.0meter 3-in-1 KVM Cable-PS/2&VGA		

Specifications subject to change without notice

# Combo DB15 LCD Console Drawers – Short Depth

Optimize rack space. Maximize rack monitoring

Rear of KVM-1501S/1701S-AST-M2

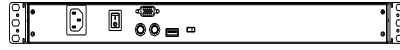

Rear of KVM-1508S/1708S-AST-M2



Rear of KVM-1516S/1716SAST-M2

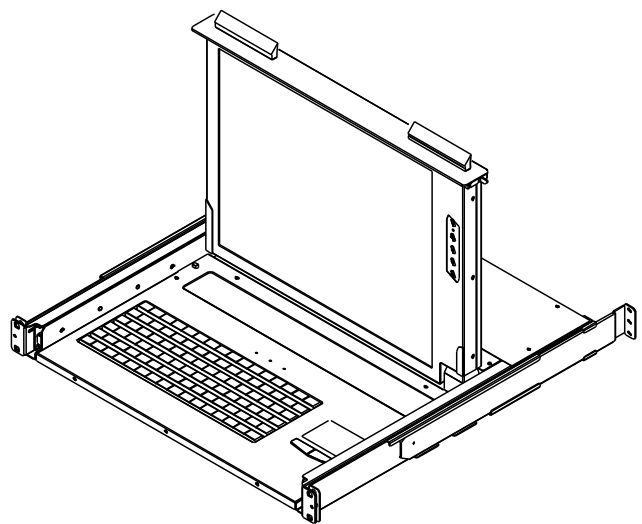
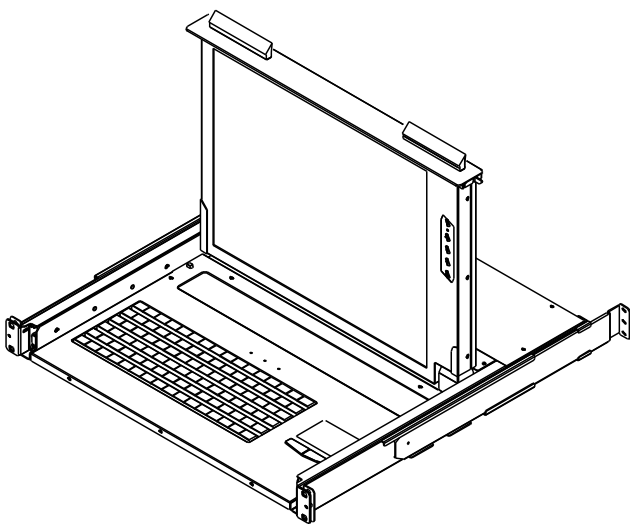
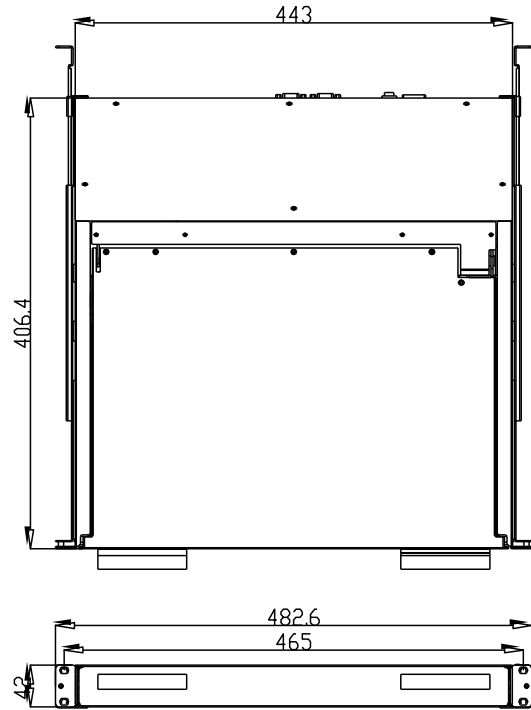
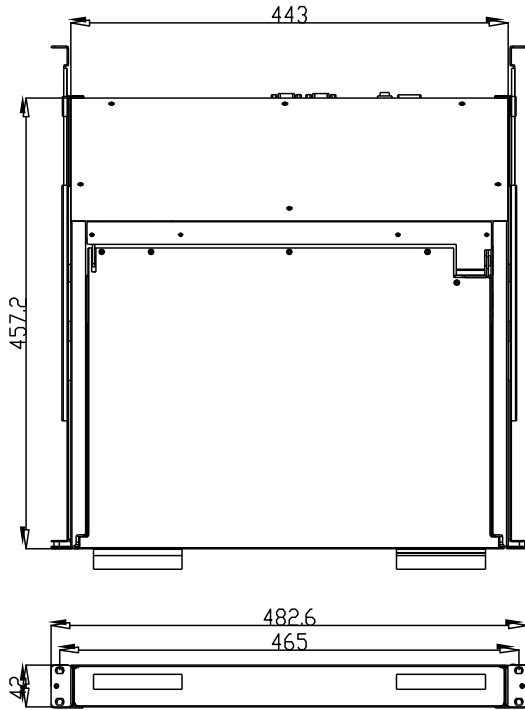

USA (Head Quarter)  
Denichi Computer Devices, Inc.  
13200 Pond Springs Rd. #A102, Austin, TX 78729  
Office: 512-837-2655  
Fax: 512-837-1694  
Email: sales@denichi.com

China (Factory)  
Add : The south faces industry area of Xia Gang Fu Hai road, Chang'an Town, Dongguan City, Guangdong, China  
Email: sales@denichi.com